



PFF3000-12-069RD

3000 W DC-DC Front-End Power Supply

PFF3000-12-069RD is a 3 kW DC/DC front-end converter that provides a main output 12.5 VDC from -40 to -72 VDC bus voltages to power Intermediate Bus Architectures (IBA) in high-performance and high-reliability servers, routers, and network switches.

Features include very high efficiency, high reliability, low output voltage noise, and excellent dynamic response to load / input changes.



Key Features & Benefits

- Best-in-class, platinum equivalent efficiency
- Input voltage range: -40 to -72 VDC
- Up to 3 kW output power - 244 A output current
- Hot-plug capable
- Parallel operation with active analog current sharing
- 2 Status LEDs: DC input OK and warning / fault signaling
- High density design: 30.5 W/in³
- Form factor: 555 x 69 x 42 mm (21.85 x 2.72 x 1.65 in)
- Full digital controls for improved performance
- RoHS Compliant
- Reverse polarity, over temperature, output overvoltage, and overcurrent protections
- I2C communication interface for control, programming, and monitoring with Power Management Bus protocol



Applications

- High Performance Servers
- Routers
- Switches



bel POWER SOLUTIONS & PROTECTION

a bel group

belfuse.com/power-solutions

1. ORDERING INFORMATION

PFF	3000	-	12	-	069	R	D	Option Code
Product Family	Power Level	Dash	V1 Output	Dash	Width	Airflow	Input	Blank: Standard model
PFF Front-Ends	3000 W		12.5 V		69 mm	R: Reversed ¹	D: DC	

¹ Front to Rear

2. OVERVIEW

PFF3000-12-069RD power supply is a fully digital controlled, highly efficient front-end converter. It incorporates state-of-the-art technology and uses an interleaved forward converter topology with active clamp and synchronous rectification to reduce component stresses, thus providing increased system reliability and very high efficiency.

With a wide DC input voltage range and minimal linear output power derating with ambient temperature, PFF3000-12-069RD maximizes power availability in demanding server, switch, and router applications. The frontend is fan cooled and ideally suited for server integration with a matching airflow path.

Active OR-ing devices on the main output ensure no reverse load current and render the supply ideally suited for operation in redundant power systems. The standby output (12V/2A) provides power to external power distribution and management controllers. Its protection with an active OR-ing device provides for maximum reliability.

Status information is provided with two front-panel LEDs. In addition, the power supply can be controlled via I2C bus. This allows full monitoring of the supply, including input and output voltage, current, power, and inside temperatures. Cooling is managed by a fan controlled by the DSP controller. The fan speed is adjusted automatically depending on the actual power demand and supply temperature and can be overridden through the I2C bus.

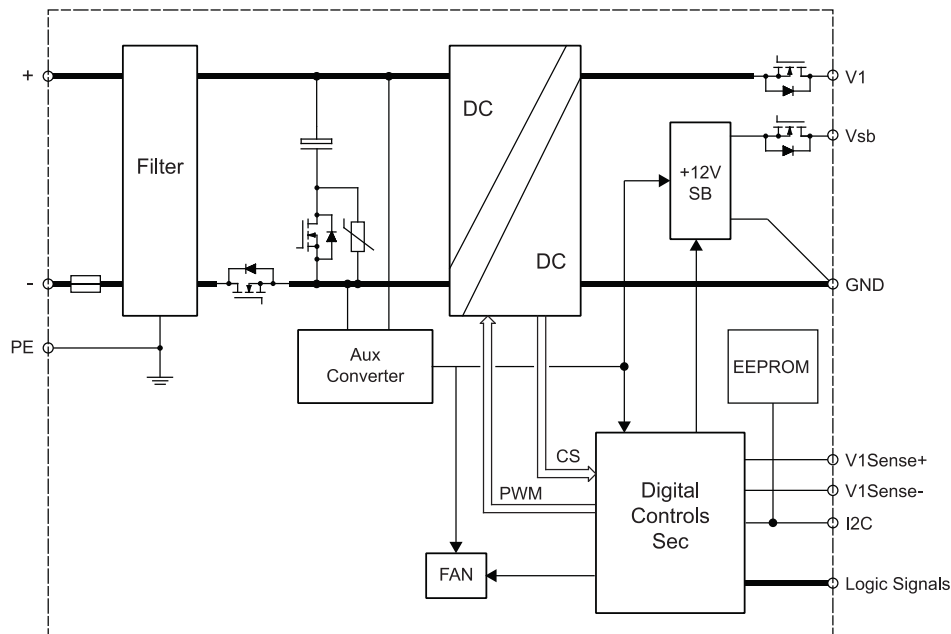

Figure 1. PFF3000-12-069RD Block Diagram

3. ABSOLUTE MAXIMUM RATINGS

Stresses in excess of the absolute maximum ratings may cause performance degradation, adversely affect long-term reliability, and cause permanent damage to the supply.

PARAMETER	CONDITIONS / DESCRIPTION	MIN	MAX	UNITS
$V_{i\ maxc}$	Maximum Input	Continuous	-75	V _{DC}

4. INPUT

General Condition: $T_A = 0 \dots 45$ °C unless otherwise noted.

PARAMETER	DESCRIPTION / CONDITION	MIN	NOM	MAX	UNIT
$V_{i\ start}$	Minimum operating input voltage	Communication available, DSP running		35	V _{DC}
$V_{i\ nom}$	Nominal input voltage		53		V _{DC}
V_i	Input voltage	Normal operation (from $V_{i\ min}$ to $V_{i\ max}$)	-40	-72	V _{DC}
I_i	Input current	$V_i > V_{i\ min}$		85	A
$I_{i\ pk}$	Inrush current limitation	From $V_{i\ min}$ to $V_{i\ max}$, $T_A = 25$ °C		100	A
$V_{i\ on_uv}$	Turn-on input voltage low	Ramping up	-42.5	-43.5	V _{DC}
$V_{i\ off_uv}$	Turn-off input voltage low	Ramping down	-38.0	-39.5	V _{DC}
$V_{i\ on_ov}$	Turn-on input voltage high	Ramping down	-68.5	-69.5	V _{DC}
$V_{i\ off_ov}$	Turn-off input voltage high	Ramping up	-72.0	-75.0	V _{DC}
H	Efficiency (fan power not included)	$V_{i\ nom}$, $0.2 \cdot I_{i\ nom}$, $V_{i\ nom}$, $T_A = 25$ °C	90.0	93.8	%
		$V_{i\ nom}$, $0.5 \cdot I_{i\ nom}$, $V_{i\ nom}$, $T_A = 25$ °C	94.0	95	%
		$V_{i\ nom}$, $I_{i\ nom}$, $V_{i\ nom}$, $T_A = 25$ °C	91.0	93	%

4.1 INPUT FUSE

Fast-acting 100 A input fuse in series on minus DC rail inside the PSU protects against severe defects. The fuse is not accessible from the outside and is not therefore a serviceable part.

4.2 INRUSH CURRENT & REVERSE POLARITY PROTECTION

Internal bulk capacitors will be charged through NTC resistors connected from bulk cap minus pin to the DC rail minus, thus limiting the inrush current. After the inrush phase, NTC resistors are then shorted with MOSFETs connected in parallel. Inrush control is managed by the digital controller (DSP).

Parallel connected MOSFETs in series to the DC minus rail input act as a reverse polarity blocking element (Fig. 1). In case of a short at the input voltage or input reverse polarity, these MOSFETs will open and prevent the bulk caps to be discharged via the input. Reverse polarity control is managed by a fast-acting analog circuit.

NOTE: In order to keep max inrush current below $I_{i\ max}$, it is not recommended to repeat plug-in/-out operations within 20 s.

4.3 INPUT UNDER-VOLTAGE

If input voltage V_i is below the input under-voltage lockout threshold $V_{i\min}$, main output will be inhibited. Once the input voltage returns within the normal operating voltage range, main output voltage will be enabled again and converter returns into normal operation.

4.4 EFFICIENCY

High efficiency is achieved by using state-of-the-art silicon power devices, thus minimizing conduction and switching losses by an optimized design and layout. Synchronous rectifiers on the output stage reduce losses in the high current output path. Fan speed is digitally controlled in order to keep all components below critical operating temperature.

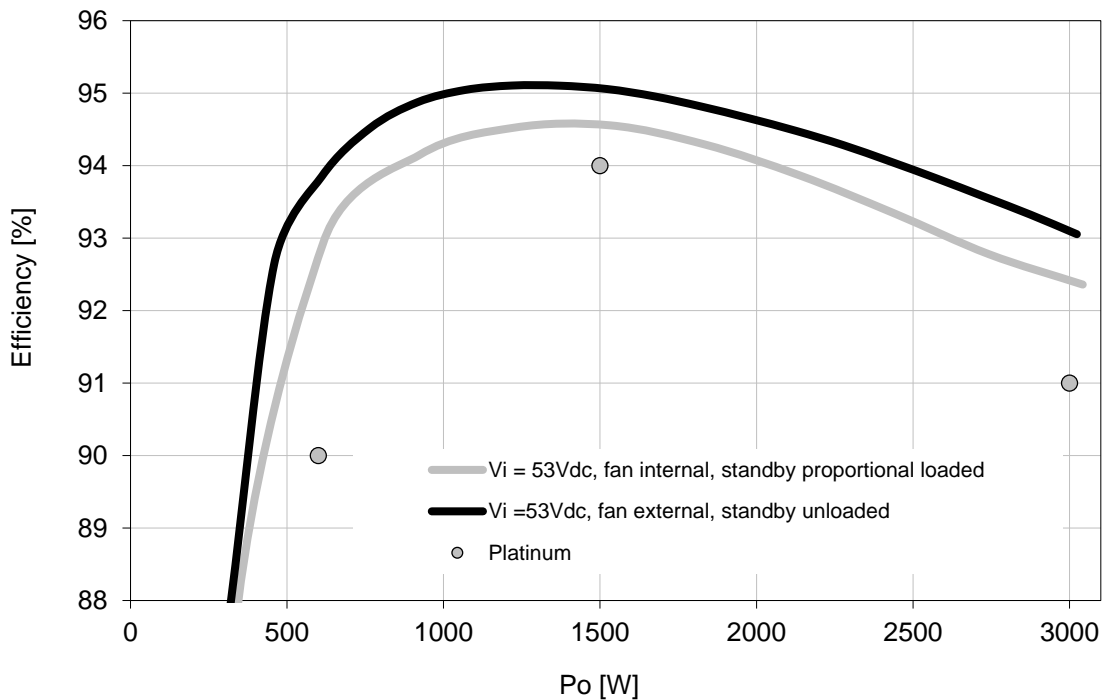

Figure 2. Efficiency vs. Load Current

5. OUTPUT

General Condition: $T_A = 0 \dots 45 \text{ }^\circ\text{C}$ unless otherwise noted.

PARAMETER	DESCRIPTION / CONDITION	MIN	NOM	MAX	UNIT	
Main Output V_1						
$V_{1 \text{ nom}}$	Nominal main output voltage	$0.5 \cdot I_{1 \text{ nom}}, T_A = 25 \text{ }^\circ\text{C}$		12.5	V_{DC}	
$V_{1 \text{ set}}$	Main output voltage set-point accuracy	$0.5 \cdot I_{1 \text{ nom}}, T_A = 25 \text{ }^\circ\text{C}$		-0.5	+0.5	% $V_{1 \text{ nom}}$
$dV_{1 \text{ tot}}$	Total regulation	$V_{1 \text{ min}}$ to $V_{1 \text{ max}}, 0$ to $100\% I_{1 \text{ nom}}, T_{A \text{ min}}$ to $T_{A \text{ max}}$		-1.0	+1.0	% $V_{1 \text{ nom}}$
$P_{1 \text{ nom}}$	Nominal main output power	$V_1 = V_{1 \text{ nom}} \pm 1.0\% V_{1 \text{ nom}}$		3000	W	
$I_{1 \text{ nom}}$	Nominal main output current	$V_1 = V_{1 \text{ nom}} \pm 1.0\% V_{1 \text{ nom}}$		244	A	
$I_{V1 \text{ lim}}$	Current limitation on V_1	See table Protection				
$I_{V1 \text{ ol}}$	Short time over load current	$V_1 = 12.3 \text{ VDC}, T_{A \text{ min}}$ to $T_{A \text{ max}},$ maximum duration 20 ms (See Section 5.2 and 6)		280	A	
$I_{V1 \text{ ol lim}}$	Current limit during short time overload I_1	See table Protection				
$V_{1 \text{ pp}}$	Main output ripple voltage	$V_{1 \text{ nom}}, I_{1 \text{ nom}}, 20 \text{ MHz BW}$		160	mV_{pp}	
$dV_{1 \text{ Load}}$	Load regulation	$V_{1 \text{ nom}}, 0 - 100\% I_{1 \text{ nom}}$		170	mV	
$dV_{1 \text{ droop}}$	Droop	$0 - 100\% I_{1 \text{ nom}}$		0.7	mV/A	
$dV_{1 \text{ Line}}$	Line regulation	$V_1 = V_{1 \text{ min}} \dots V_{1 \text{ max}}$		0	mV	
dI_{share}	Current sharing accuracy	Deviation $I_{1 \text{ tot}} / N, I_1 > 30\% I_{1 \text{ nom}}$		-5	+5	%
$dV_{1 \text{ dyn}}$	Dynamic load regulation	$I_1 = 10\% \dots 50\% I_{1 \text{ nom}}, I_{1 \text{ tot}} = I_1 + \Delta I_1, \Delta I_1 = 50\% I_{1 \text{ nom}}, dI_0 / dt = 1 \text{ A}/\mu\text{s},$ recovery within 1% of $V_{1 \text{ nom}}$		-0.6	+0.6	V
$T_{1 \text{ rec}}$	Recovery time			1	ms	
$t_{V1 \text{ Pwr_On}}$	Start-up time from DC input	$V_1 = 10.8 V_{\text{DC}}$		See table on/ off signal timings		
$t_{V1 \text{ rise}}$	Rise time (monotonic)	$V_1 = 10\% \dots 90\% V_{1 \text{ nom}}, 50\% I_{1 \text{ nom}}$		4.5	ms	
$t_{V1 \text{ holdup}}$	Hold-up time	$0.5 \cdot I_1, V_1 = V_{1 \text{ nom}}$		2	ms	
C_{load}	Capacitive loading	$T_A = 25 \text{ }^\circ\text{C}$		10000	μF	
Standby Output V_{SB}						
$V_{\text{SB nom}}$	Nominal standby output voltage	$0.5 \cdot I_{\text{SB nom}}, T_A = 25 \text{ }^\circ\text{C}$		12.00	V_{DC}	
$V_{\text{SB set}}$	Standby output set-point accuracy	$0.5 \cdot I_{\text{SB nom}}, T_A = 25 \text{ }^\circ\text{C}$		-1.0	+1.0	% $V_{\text{SB nom}}$
$dV_{\text{SB tot}}$	Total regulation	$V_{1 \text{ min}}$ to $V_{1 \text{ max}}, 0$ to $100\% I_{\text{SB nom}}, T_{A \text{ min}}$ to $T_{A \text{ max}}$		-1.0	+1.0	% $V_{\text{SB nom}}$
$P_{\text{SB nom}}$	Nominal standby output power	$V_{\text{SB}} = V_{\text{SB nom}} \pm 0.5\% V_{\text{SB nom}}$		24	W	
$I_{\text{SB nom}}$	Nominal standby output current	$V_{\text{SB}} = V_{\text{SB nom}} \pm 0.5\% V_{\text{SB nom}}$		2	A	
$V_{\text{SB pp}}$	Standby output ripple voltage	$V_{\text{SB nom}}, I_{\text{SB nom}}, 20 \text{ MHz BW}$		120	mV_{pp}	
$I_{\text{VSB lim}}$	Current limit	See table Protection				
$t_{\text{VSB lim}}$	Over load current limit time on V_{SB}	Time to hit hiccup when in over current		See table Protection		
dV_{SB}	Load regulation	$0 - 100\% I_{\text{SB nom}}$		220	mV	
	Droop	$0 - 100\% I_{\text{SB nom}}$		110	mV/A	
$dV_{\text{SB dyn}}$	Dynamic load regulation	$I_{\text{SB}} = 5\% \dots 50\% I_{\text{SB nom}}, I_{\text{SB tot}} = I_1 + \Delta I_1, \Delta I_{\text{SB}} = 50\% I_{\text{SB nom}}, dI_0 / dt = 1 \text{ A}/\mu\text{s},$ recovery within 1% of $V_{\text{SB nom}}$		-0.6	+0.6	V
$T_{\text{SB rec}}$	Recovery time			5	ms	
$t_{\text{VSB Pwr_On}}$	Start-up time from DC input	$V_{\text{SB}} = 90\% V_{\text{SB nom}}$		See table on/ off signal timings		
$t_{\text{VSB rise}}$	Rise time (monotonic)	$V_{\text{SB}} = 10\% \dots 90\% V_{\text{SB nom}}$		0.1	ms	
$t_{\text{VSB holdup}}$	Hold-up time	$I_{\text{sb}} = 0 \dots 2\text{A}, V_1 > 48\text{V}$		5	260	ms
C_{load}	Capacitive loading	$T_A = 25 \text{ }^\circ\text{C}$		1000	μF	

5.1 OUTPUT VOLTAGE RIPPLE

The internal output capacitance at the power supply output (behind OR-ing element) is minimized to prevent disturbances during hot plug. In order to provide low output ripple voltage in the application, external capacitors should be added close to the power supply output. The setup of *Figure 3* has been used to evaluate suitable capacitor types. The capacitor combinations of Table 1 and Table 2 should be used to reduce the output ripple voltage.

The ripple voltage is measured with 20 MHz BWL, close to the external capacitors.

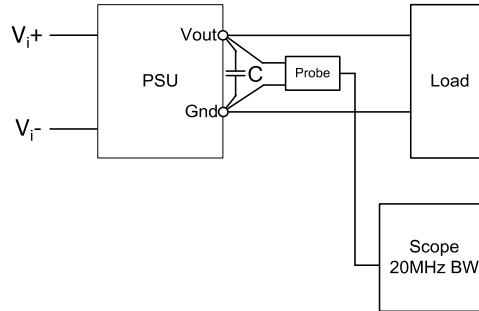

Figure 3. Output Ripple Test Setup

NOTE: Care must be taken when using ceramic capacitors with a total capacitance of 1 μ F to 50 μ F on output V1, due to their high quality factor the output ripple voltage may be increased in certain frequency ranges due to resonance effects.

External Capacitor V1	dV1max	Unit
2Pcs 47 μ F/16V/X5R/1210	160	mVpp
1Pcs 1000 μ F/16V/Low ESR Aluminum/ ϕ 10x20	160	mVpp
1Pcs 270 μ F/16V/Conductive Polymer/ ϕ 8x12	160	mVpp
2Pcs 47 μ F/16V/X5R/1210 plus 1Pcs 270 μ F Conductive Polymer OR 1Pcs 1000 μ F Low ESR AlCap	90	mVpp

Table 1. Suitable Capacitors for V1

External capacitor VSB	dVSBmax	Unit
1Pcs 270 μ F/16V/Conductive Polymer/ ϕ 8x12	120	mVpp

Table 2. Suitable Capacitors for VSB

The output ripple voltage on VSB is influenced by the main output V1. Evaluating VSB output ripple must be done when maximum load is applied to V1.

5.2 OUTPUT ISOLATION

Main and standby outputs and all signals are galvanic isolated from the chassis and protective earth connection, although the applied voltage V_i has not to exceed $75 V_{pk}$ in order to prevent catastrophic damage to the PSU.

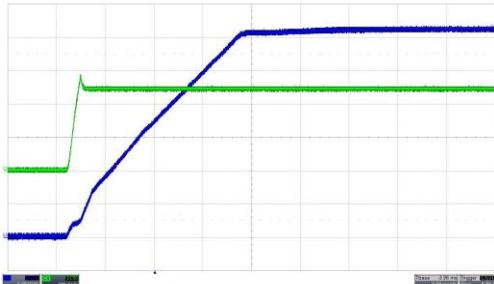

Figure 4. Turn-on at $V_i = V_{i-nom}$, $I_i = I_{i-nom}$ (2 ms/div)
CH3 (blue): V_i (2 V/div), CH4 (green): I_i (100 A/div)

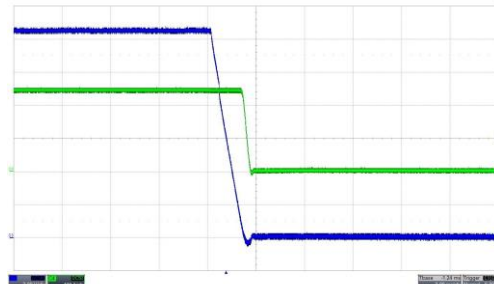

Figure 5. Turn-off at $V_i = V_{i-nom}$, $I_i = I_{i-nom}$ (2 ms/div)
CH3 (blue): V_i (2 V/div), CH4 (green): I_i (100 A/div)

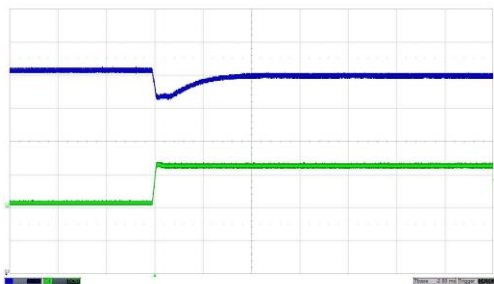

Figure 6. Load transient on V_i , 12 A to 122 A (1 ms/div)
CH3 (blue): V_i (0.5 V/div), CH4 (green): I_i (100 A/div)

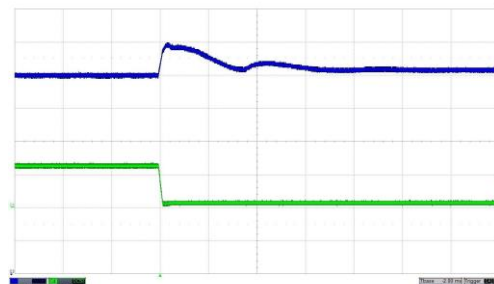

Figure 7. Load transient on V_i , 122 A to 12 A (1 ms/div)
CH3 (blue): V_i (0.5 V/div), CH4 (green): I_i (100 A/div)

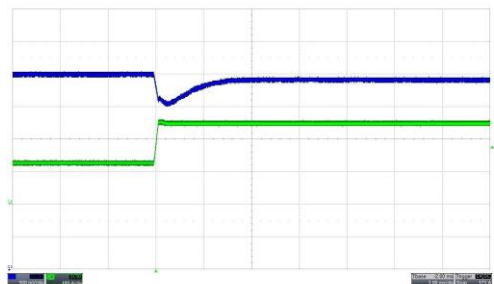

Figure 8. Load transient on V_i , 122 A to 244 A (1 ms/div)
CH3 (blue): V_i (0.5 V/div), CH4 (green): I_i (100 A/div)

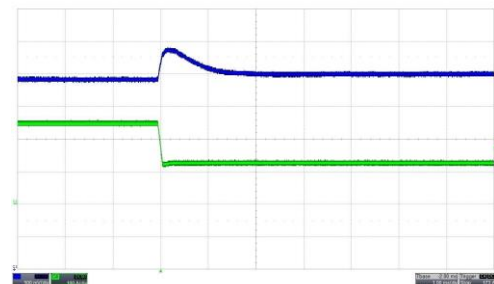

Figure 9. Load transient on V_i , 244 A to 122 A (1 ms/div)
CH3 (blue): V_i (0.5 V/div), CH4 (green): I_i (100 A/div)

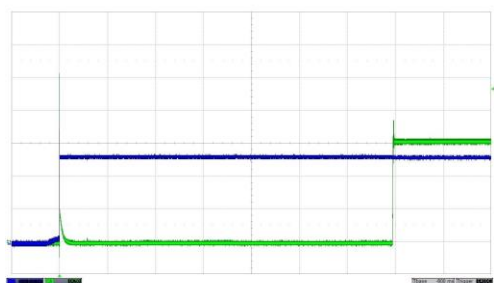

Figure 10. Inrush current, $V_i = V_{i-nom}$, $I_i = I_{i-nom}$ (200 ms/div)
CH3 (blue): V_{IN} (20 V/div), CH4 (green): I_{IN} (20 A/div)

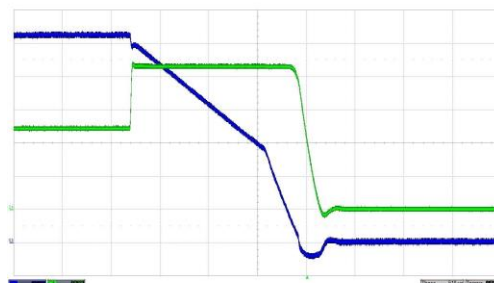

Figure 11. Short circuit on main output (500 μ s/div)
CH3 (blue): V_i (2 V/div), CH4 (green): I_i (100 A/div)

6. PROTECTION

PARAMETER	DESCRIPTION / CONDITION		MIN	NOM	MAX	UNIT
F	Input fuse	Not user-accessible, quick-acting		100		A
V_1 OV	Overvoltage threshold on V_1		13.6	14.2	14.8	V_{DC}
$t_{OV V_1}$	Overvoltage latch-off time on V_1				1	ms
$V_{SB OV}$	Overvoltage threshold on V_{SB}		13.3	13.9	14.5	V_{DC}
$t_{OV V_{SB}}$	Overvoltage latch-off time on V_{SB}				1	ms
$I_{V_1 lim}$	Current limitation on V_1	$T_a < 45^\circ\text{C}$ $T_a = 60^\circ\text{C}$ ¹	246 198		260 212	A
$t_{V_1 lim}$	Current limit blanking time on V_1	Time to latch off when in over current	22	30	35	ms
$I_{V_1 ol lim}$	Current limit during short time overload I_1		292		308	A
$I_{V_1 SC}$	Max Short Circuit Current I_1	$V_1 < 3\text{ V}$			350 ²	A
$t_{V_1 SC}$	Short circuit latch off time	Measured from $V_1 < 8.0\text{ V}$		1		ms
$I_{V_{SB} lim}$	Current limitation on V_{SB}		2.5		3.5	A
$t_{V_{SB} lim}$	Current limit blanking time on V_{SB}	Time to enter hiccup when in overcurrent			1	ms
T_{SD}	Over temperature on critical points	Inlet ambient temperature		60		$^\circ\text{C}$
		Secondary Sync. MOSFETs temperature		115		$^\circ\text{C}$
		Secondary OR-ing MOSFETs temperature		125		$^\circ\text{C}$

¹ See *Figure 26* for linear power derating > 45°C

² Limit set don't include effects of main output capacitive discharge.

6.1 AUTOMATIC RETRY

Any fault condition on main output V_1 will shut down the main output and attempt to recover from the fault 5 times before latching off. The time between each restart attempt is 10 s. The fault latch and fault counter can be reset by disconnecting the input voltage or by toggling the PSON_L input. If the unit operates for more than 10 min with no failure, then the failure counter will be reset automatically. A failure on the standby output V_{SB} will shut down both outputs, whereas a failure on main output V_1 will only shut down this output, while V_{SB} will continue to operate and communicate.

6.2 OVERVOLTAGE PROTECTION

The PSU provides a fixed threshold overvoltage (OV) protection, implemented with a hardware comparator. Once an overvoltage (OV) condition has been triggered, the supply will shut down and latch the fault condition.

6.3 UNDERVOLTAGE DETECTION

As both main and standby outputs are monitored, LEDs and the PWOK_L pin will warn if V_1 or V_{SB} exceed $\pm 7\%$ of its nominal voltage. Output undervoltage protection is provided on both outputs. When either V_1 or V_{SB} falls below 93% of its nominal voltage, the output is inhibited.

6.4 OUTPUT OVER-CURRENT PROTECTION

MAIN OUTPUT

Two different over current protection features are implemented on the main output.

The 1st protection - a static over current protection will shut down the output, if the output current does exceed $I_{V1\ lim}$ for more than 20 ms. If the output current is increased slowly this protection will shut down the supply. The main output current limitation level $I_{V1\ lim}$ will decrease if the ambient (inlet) temperature increases beyond 45 °C (see *Figure 26*).

The 2nd protection - a substantially rectangular output characteristic controlled by a software feedback loop. This protects the power supply and system during the 20 ms blanking time of the static over current protection. If the output current is rising fast and reaches $I_{V1\ ol\ lim}$, the supply will immediately reduce its output voltage to prevent the output current from exceeding $I_{V1\ ol\ lim}$. When the output current is reduced below $I_{V1\ ol\ lim}$, the output voltage will return to its nominal value.

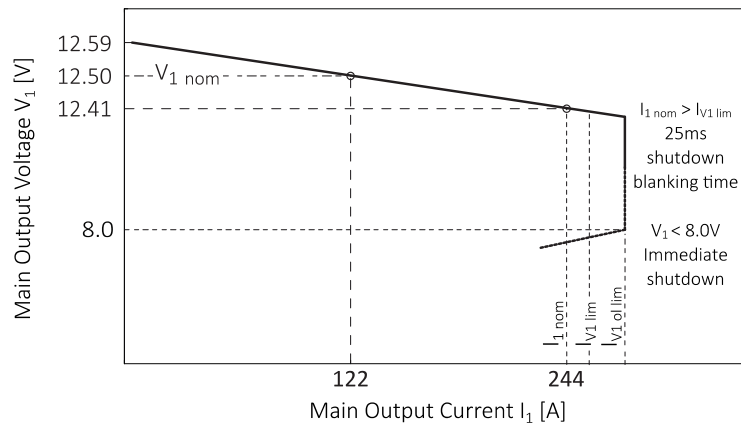

Figure 12. Current limitation on main output

STANDBY OUTPUT

On the standby output a hiccup type over current protection is implemented. This protection will shut down the standby output immediately when standby current reaches or exceeds $I_{VSB\ lim}$. After an off-time of 1s the output automatically tries to restart. If the overload condition is removed the output voltage will reach again its nominal value $V_{SB} = V_{SB\ nom} \pm 1\%$. At continuous overload condition the output will repeatedly trying to restart with 1s intervals.

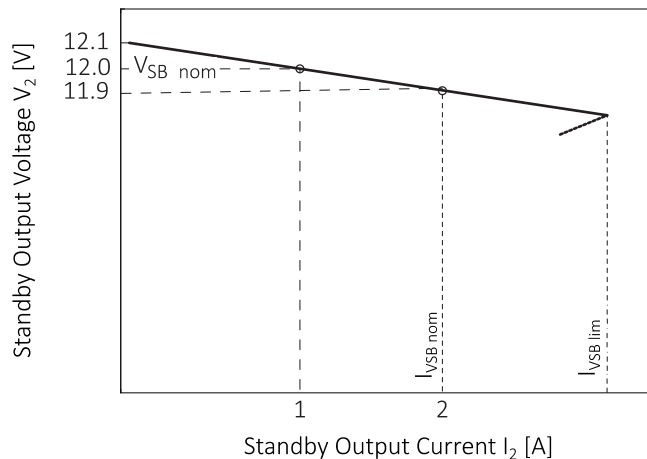

Figure 13. Current limitation on standby output

7. MONITORING

PARAMETER	DESCRIPTION / CONDITION	MIN	NOM	MAX	UNIT	
$V_{I\ mon}$	Input voltage	$V_{I\ min} \leq V_I \leq V_{I\ max}$		-2.5	+2.5	%
$I_{I\ mon}$	Input current	$I_I > 20\ A$ $8\ A < I_I \leq 20\ A$		-5.0	+5.0	%
$P_{I\ mon}$	Input power	$P_I > 700\ W$ $330\ W < P_I \leq 700\ W$		-5.0	+5.0	%
$V_{1\ mon}$	Main output voltage			-2	+2	%
$I_{1\ mon}$	Main output current	$I_1 > 134\ A$ $24\ A < I_1 \leq 75\ A$		-2.0	+2.0	%
$P_{o1\ mon}$	Main output power	$P_{o1} > 400\ W$ $300\ W < P_{o1} \leq 400\ W$		-5	+5	%
$V_{SB\ mon}$	Standby voltage			-2	+2	%
$I_{SB\ mon}$	Standby current			-0.2	0.2	A
$P_{SB\ mon}$	Standby output power			-2.4	2.4	W

8. SIGNALING AND CONTROL

8.1 ELECTRICAL CHARACTERISTICS

PARAMETER	DESCRIPTION / CONDITION	MIN	NOM	MAX	UNIT
PSKILL / PSKILL_IN / PSON_L inputs					
V_{IL}	Input low level voltage	-0.2		+0.8	V
V_{IH}	Input high level voltage	2.0		3.6	V
$I_{IL, H}$	Maximum input sink or source current	0		1	mA
$R_{pu\ PSKILL_IN}$	Internal pull-up resistor on PSKILL		10		k Ω
$R_{pu\ PSON_L}$	Internal pull-up resistor on PSON_L		10		k Ω
PWOK_L output					
V_{OL}	Output level voltage	$I_{sink} < 4\ mA$	-0.2	0.4	V
$V_{pu\ PWOK_L}$	External pull-up voltage			12	V
$R_{pu\ PWOK_L}$	Recommended external pull-up resistor on PWOK_L at $V_{pu\ PWOK_L} = 3.3\ V$		10		k Ω
Low level output	All outputs are turned on and within regulation				
High level output	In standby mode or V_1 / V_{SB} have triggered a fault condition				
INOK_L output					
V_{OL}	Output low level voltage	$I_{sink} < 4\ mA$	-0.2	0.4	V
$V_{pu\ INOK_L}$	External pull-up voltage			12	V
$R_{pu\ INOK_L}$	Recommended external pull-up resistor on INOK_L at $V_{pu\ INOK_L} = 3.3\ V$		10		k Ω
Low level output	Input voltage is within range for PSU to operate				
High level output	Input voltage is not within range for PSU to operate				
SMB_ALERT_L output					
V_{OL}	Output low level voltage	$I_{sink} < 4\ mA$	-0.2	0.4	V
$V_{pu\ SMALT_L}$	External pull-up voltage			12	V
$R_{pu\ SMALT_L}$	Recommended external pull-up resistor on SMB_ALERT_L at $V_{pu\ SMALT_L} = 3.3\ V$		10		k Ω
Low level output	PSU is in warning or failure condition				
High level output	PSU is ok				

8.2 INTERFACING WITH SIGNALS

A 15 V Zener diode is added on all signal pins versus signal ground SGND to protect internal circuits from negative and high positive voltage. Signal pins of several supplies running in parallel can be interconnected directly. A supply having no input power will not affect the signals of other PSUs running in parallel.

The current share bus pin (ISHR_BUS) must be interconnected without any additional components; as protection element, a 15 V Zener diode is connected to the signal reference SGND. The share bus is disconnected (analog switch) from internal circuits when the power supply is switched off.

8.3 LED STATUS - FRONT LEDs

The PSU has two front LEDs showing its status: DC Input LED is green colored and indicates DC power ON / OFF, DC Output LED is bi-colored green and yellow and shows DC output OK or a warning/fault status as listed in Table 1.

OPERATING CONDITION	LED SIGNALING
IN: DC Input LED	
DC line within range	Solid Green
DC line UV / OV condition	OFF
Bootload	Blinking green: OFF (1:1)
OUT: DC Output LED	
Normal Operation	Solid Green
PSKILL_IN_L - Left open	Blinking Yellow (1:1)
PSON_L - High, PSKILL_L - High	
Power Management Bus Command OPERATION	
DC line UV / OV condition	
V1 or VSB out of regulation	Solid Yellow
Over temperature shutdown	
Output over voltage shutdown (V ₁ or V _{SB})	
Output under voltage shutdown (V ₁ or V _{SB})	
Output over current shutdown (V ₁ or V _{SB})	Blinking Yellow/Green (2:1)
Both FANs blocked	
Over temperature warning	
Minor fan regulation error (> 5 %, < 15 %)	
Or one of the FANs blocked	Blinking Yellow/Green (1:1)
Bootload	
Bootload	Blinking Green (1:1)

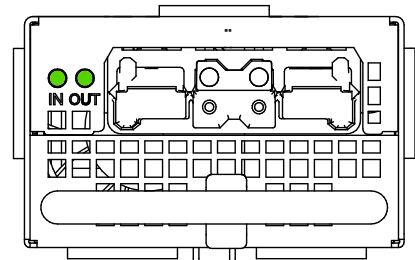

Table 3. LED Status

8.4 PRESENT_L

PRESENT_L is a trailing pin within the connector and will contact only once all other connector contacts. This active-low pin is used to indicate to a power distribution unit controller that a supply is plugged in. Maximum sink current on PRESENT_L pin should not exceed 10 mA.

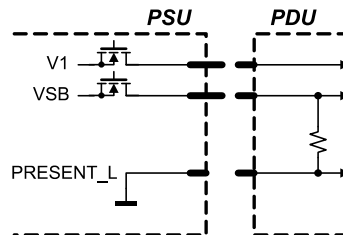

Figure 14. PRESENT_L signal pin

8.5 PSKILL_L / PSKILL_IN_L INPUT

PSKILL_L input is an active-low trailing pin in the output connector and is used to disconnect the main output as soon as the power supply is being pulled out. This pin should be connected to SGND in the power distribution unit. Standby output will remain on, regardless of the PSKILL_L input state.

PSKILL_IN_L input is an active-low signal pin in the input connector and is used to disconnect the main output as soon as the input connector is plugged out. This pin should be connected to SGND on the input connector mating part. Standby output will remain on, regardless of the PSKILL_L input state.

8.6 DC TURN-ON / DROP-OUTS / INOK_L

The INOK_L signal indicates whether the DC input voltage is within the operating range and the power supply can turn on. The power supply will automatically turn-on when connected to the DC line within the operating voltage range under the condition that the PSON_L signal is pulled low. INOK_L is an active low open collector output that requires an external pull-up voltage to maximum 12.0 V.

8.7 PSON_L INPUT

PSON_L is an internally pulled-up (3.3 V) input signal to enable / disable the main output V_1 . This active-low pin is also used to clear any latched fault condition. Timing parameters are listed in Table 2.

8.8 PWOK_L SIGNAL

PWOK_L is an open collector output that requires an external pull-up voltage to maximum 12 V, indicating whether both V_1 and V_{SB} outputs are within regulation. This pin is active-low; timing parameters are listed in Table 2.

8.9 SIGNAL TIMING

OPERATING CONDITION		MIN	MAX	UNIT
t_{V1_rise}	See table Output Parameter			
t_{VSB_rise}	See table Output Parameter			
t_{INOK_On}	INOK_L delay at dropout	0	700	ms
$t_{INOK_On_Pwr_On}$	INOK_L delay at coldstart	500	1800	ms
$t_{INOK_to_VSB_rise}$	INOK_L to V_{SB} delay	1	5	ms
$t_{VSB_Pwr_On}$	V_{in} to V_{SB} delay	520	1805	ms
$t_{V1_Pwr_On}$	V_{in} to V_1 delay	700	3000	ms
t_{PWOK_On}	V_1 in regulation to PWOK_L	280	320	ms
t_{V1_fall}	monotonic			
t_{VSB_fall}	monotonic			
t_{INOK_Off}	INOK_L delay	0	1.8	ms
t_{INOK_warn}	INOK_L to V_1 out of regulation ($0.5 I_1$), $V_1 > 48V$	1.0		ms
t_{V1_holdup}	See table Output Parameter			
t_{VSB_holdup}	See table Output Parameter			
t_{PWOK_Off}	V_1 out of regulation to PWOK_L	0	5	ms
t_{PSON_On}	PSON_L to V_1 in regulation	150	170	ms
t_{PSON_Off}	PSON_L to V_1 out of regulation	0	5	ms
$t_{PSKILL_IN_On}$	PSKILL(IN)_L to V_1 in regulation	150	170	ms
$t_{PSKILL_IN_Off}$	PSKILL(IN)_L to V_1 out of regulation	0	5	ms

Table 4. On-/Off- Signal Timings

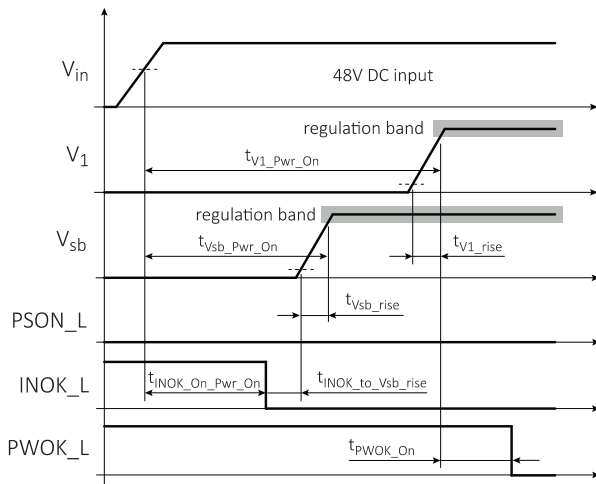

Figure 15. Power on Delay, Rise Time and Signaling

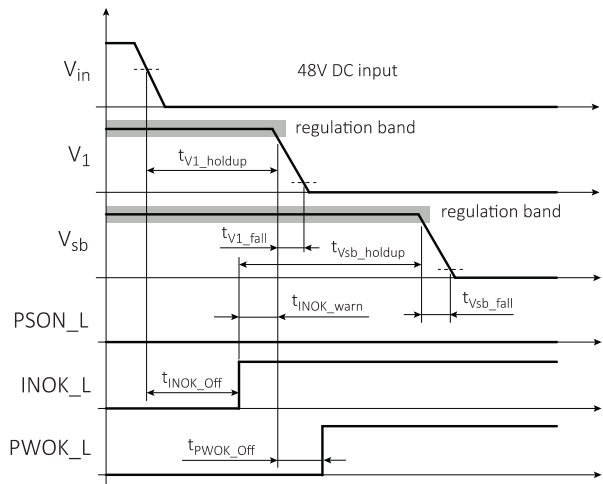

Figure 16. Power Removed Holdup, Fall Time and Signaling

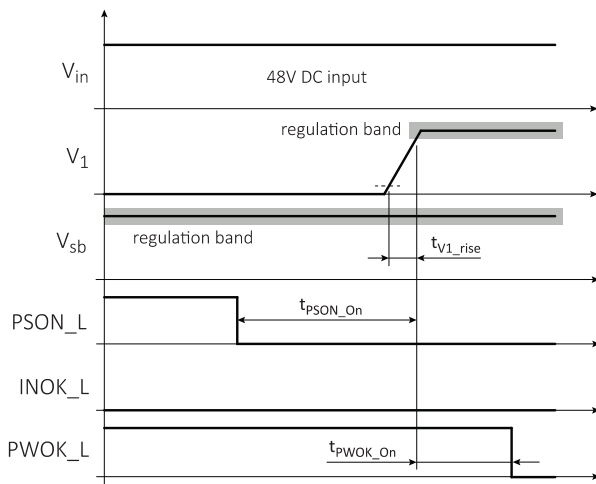

Figure 17. Turn On Delay, Rise Time and Signaling

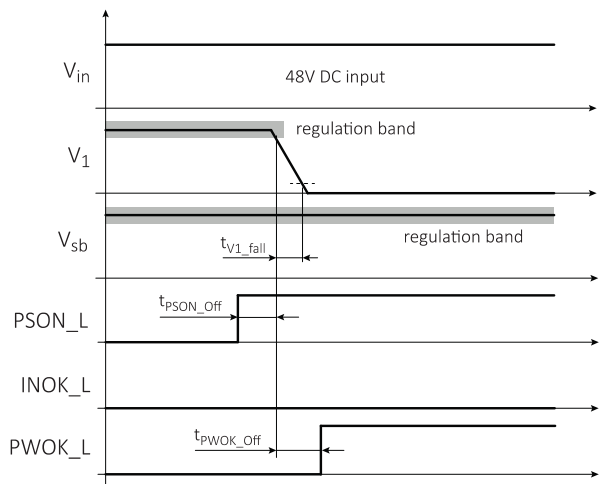

Figure 18. Turn Off, Fall Time and Signaling

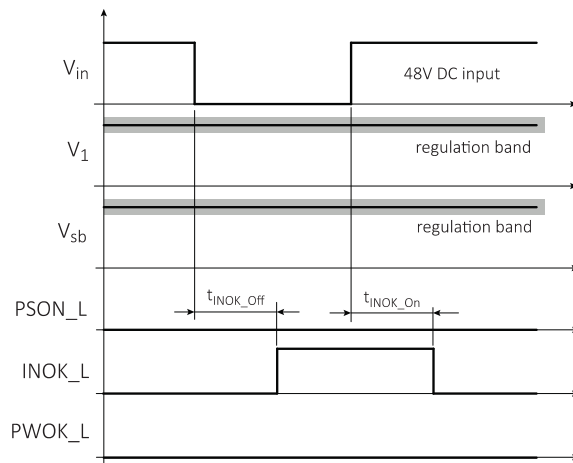

Figure 19. Dropout and Signaling

8.10 CURRENT SHARE

The PSU has an active current share scheme implemented for main output V_1 . ISH_BUS current share pins of all units in parallel need to be interconnected in order to activate the sharing function. If a supply has an internal fault or is not turned on, it will disconnect its ISHR_BUS pin from the share bus: this will prevent dragging the output down (or up) in such cases.

Master / Slave current share function implemented by the controller uses an analog bus: the power supply providing the largest current among the group is automatically the Master. The other supplies will operate as Slaves and increase their output current to a value close to the Master by slightly increasing their output voltage. The output voltage increase is limited to +250 mV. Standby output uses an analog passive current-share method (droop-output voltage characteristic).

Maximum available main and stand-by power in (non)-redundant topology is listed in Table 5.

No. of paralleled PSUs	Max available power on main output without redundancy	Max available power on main output with n+1 redundancy	Max available power on standby output
1	3000 W	-	24 W
2	5850 W	3000 W	24 W
3	8700 W	5850 W	24 W
4	11550 W	8700 W	24 W
5	14400 W	11550 W	24 W
6	17250 W	14400 W	24 W

Table 5. Available power when multiple PSUs are operating

8.11 SENSE INPUTS

Main output sense lines have been implemented in order to compensate voltage drops on the load wires: a maximum voltage drop of 200 mV on the positive rail and 100 mV on the PGND rail is allowed. If sense inputs are not connected (open), main output voltage will rise by 250 mV; therefore, if sense inputs are not used, they should be connected to the power output and SGND, close to the power supply connector. The sense inputs are protected against short circuit and reverse polarity. If the sense lines are shorted (or reverse polarized) at start-up condition, then V_1 will be regulated by 500 mV higher than the reference voltage for 100 ms and later the PSU will shut down reporting a sense fault error. If the sense lines are shorted (or reverse polarized) during operation, then the unit will shut down immediately.

8.12 I2C / POWER MANAGEMENT BUS COMMUNICATION

The PSU is a communication slave device only: it never initiates messages on the I2C / SMBus. It recognizes any time Start / Stop bus conditions and the interface driver in the supply is referred to the SGND. Communication bus voltage and timing are defined by:

- 100 k Ω internal pull-up resistors
- SDA / SCL IOs must be pull-up externally to 3.3 ± 0.3 V
- Pull-up resistor should be 2 k Ω to 5 k Ω to ensure SMBUS compliant signal rise times
- Full SMBus clock speed of 100 kbps
- Clock stretching limited to 1 ms
- SCL low time-out of > 25 ms with recovery time within 10 ms

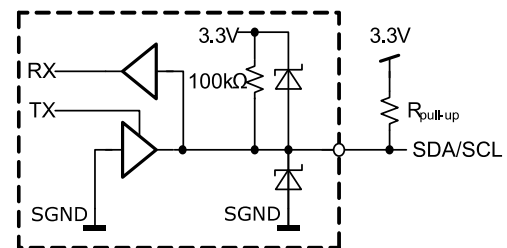

Figure 20. Physical layer of communication interface

SMB_ALERT_L signal indicates that the power supply is experiencing a problem that the system agent should investigate: this is a logical OR of the shutdown and warning events. Communication to the DSP will be possible as long as the input voltage is provided. If no input voltage is present, communication to the unit is possible as long as it is connected to a live V_{SB} output (e.g. provided by a redundant unit); if only V_1 is provided, communication is not possible.

PARAMETER	CONDITION	MIN	MAX	UNIT	
V_{IL}	Input low voltage	-0.2	0.4	V	
V_{IH}	Input high voltage	2.1	3.6	V	
V_{hys}	Input hysteresis	0.15		V	
V_{oL}	Output low voltage	4 mA sink current	0	0.4	V
t_r	Rise time for SDA and SCL	$20 + R_b C_b^1$	300	ns	
t_{of}	Output fall time $V_{IHmin} \rightarrow V_{ILmax}$	$10 \text{ pF} < C_b^1 < 400 \text{ pF}$	$20 + R_b C_b^1$	250	ns
I_i	Input current SCL / SDA	$0.1 V_{DD} < V_i < 0.9 V_{DD}$	-10	10	μA
C_i	Capacitance for each SCL / SDA		10	pF	
f_{SCL}	SCL clock frequency	0	100	kHz	
R_{pu}	External pull-up resistor		$1000 \text{ ns} / C_b^1$	Ω	
t_{HDSTA}	Hold time (repeated) START	$f_{SCL} \leq 100 \text{ kHz}$	4.0	μs	
t_{LOW}	Low period of the SCL clock	$f_{SCL} \leq 100 \text{ kHz}$	4.7	μs	
t_{HIGH}	High period of the SCL clock	$f_{SCL} \leq 100 \text{ kHz}$	4.0	μs	
t_{SUSTA}	Setup time for a repeated START	$f_{SCL} \leq 100 \text{ kHz}$	4.7	μs	
t_{HDDAT}	Data hold time	$f_{SCL} \leq 100 \text{ kHz}$	0	3.45	μs
t_{SUDAT}	Data setup time	$f_{SCL} \leq 100 \text{ kHz}$	250	μs	
t_{SUSTO}	Setup time for STOP condition	$f_{SCL} \leq 100 \text{ kHz}$	4.0	μs	
t_{BUF}	Bus free time between STOP and START	$f_{SCL} \leq 100 \text{ kHz}$	4.7	μs	
EEPROM_WP					
V_{IL}	Input low voltage	-0.2	0.4	V	
V_{IH}	Input high voltage	2.1	3.6	V	
I_i	Input sink or source current	-1	1	mA	
R_{pu}	Internal pull-up resistor to 3.3V		10k	Ω	

¹ C_b = Bus line capacitance in pF, typically in the range of 10 pF...400 pF, $R_b = 100 \Omega$

Table 6. I2C / SMBus Specification

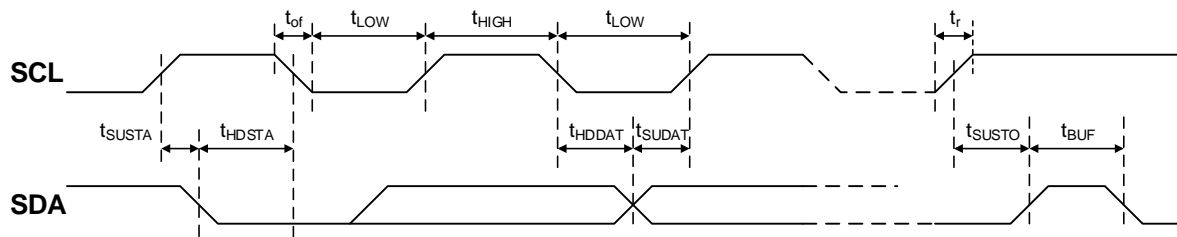

Figure 21. I2C / SMBus Timing

8.13 ADDRESS

The unit supports the Power Management Bus communication protocol with a fixed address at 0x20. The EEPROM is at fixed address = 0xA0.

8.14 CONTROLLER ACCESS

The controller and the EEPROM in the power supply share the same I2C bus physical layer (see Figure 23). In order to write to the EEPROM, the write protection needs to be disabled by setting EEPROM_WP input correctly. EEPROM_WP=HIGH: write disabled; EEPROM_WP=LOW: write enabled.

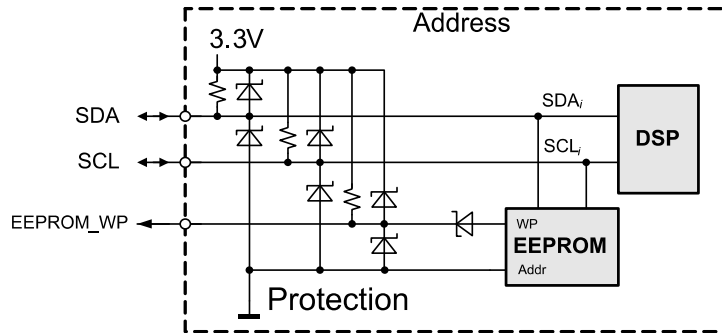

Figure 22. I2C Bus to Controller and EEPROM

8.15 EEPROM PROTOCOL

The EEPROM follows the industry communication protocols used for this type of device. Even though page write / read commands are defined, it is recommended to use the single byte write / read commands.

WRITE

The write command follows the SMBus 1.1 Write Byte protocol. After the device address with the write bit cleared a first byte with the data address to write to is sent followed by the data byte and the STOP condition. A new START condition on the bus should only occur after 5ms of the last STOP condition to allow the EEPROM to write the data into its memory.



READ

The read command follows the SMBus 1.1 Read Byte protocol. After the device address with the write bit cleared the data address byte is sent followed by a repeated start, the device address and the read bit set. The EEPROM will respond with the data byte at the specified location.

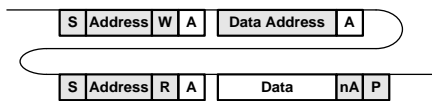

8.16 POWER MANAGEMENT BUS PROTOCOL

The Power Management Bus is an open standard protocol that defines means of communicating with power conversion and other devices. For more information, please see the System Management Interface Forum web site at: www.powerSIG.org.

Power Management Bus command codes are not register addresses. They describe a specific command to be executed. PFF3000-12-069RD supply supports the following basic command structures:

- Clock stretching limited to 1 ms
- SCL low time-out of >25 ms with recovery within 10 ms
- Recognized any time Start/Stop bus conditions

WRITE

The write protocol is the SMBus 1.1 Write Byte/Word protocol. Note that the write protocol may end after the command byte or after the first data byte (Byte command) or then after sending 2 data bytes (Word command).

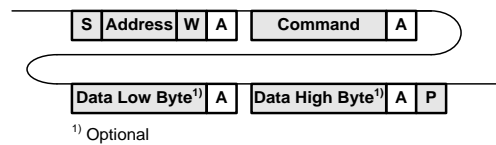

In addition, Block write commands are supported with a total maximum length of 255 bytes. See PFF3000-12-069RA Power Management Bus Communication Manual BCA.00070 for further information.

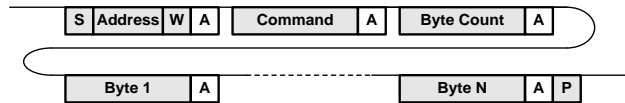

READ

The read protocol is the SMBus 1.1 Read Byte/Word protocol. Note that the read protocol may request a single byte or word.

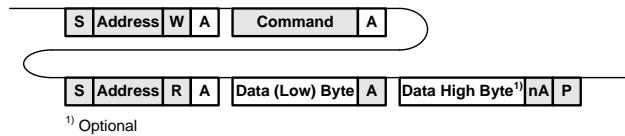

In addition, Block read commands are supported with a total maximum length of 255 bytes. See PFF3000-12-069RD Power Management Bus Communication Manual BCA.00216 for further information.

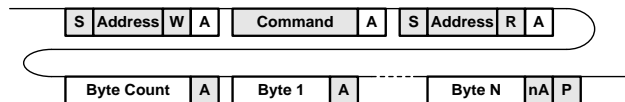

8.17 GRAPHICAL USER INTERFACE

Bel Power Solutions provides its I2C Utility: a Windows® XP / Vista / Win7 compatible graphical user interface (GUI), allowing PFF3000-12-069RD programming and monitoring. This utility can be downloaded at belfuse.com/power-solutions and supports both the PSI and Power Management Bus protocols. The GUI allows automatic finding of connected units to the communication bus and will show them in the navigation tree. In the monitoring view the power supply can be controlled and monitored.

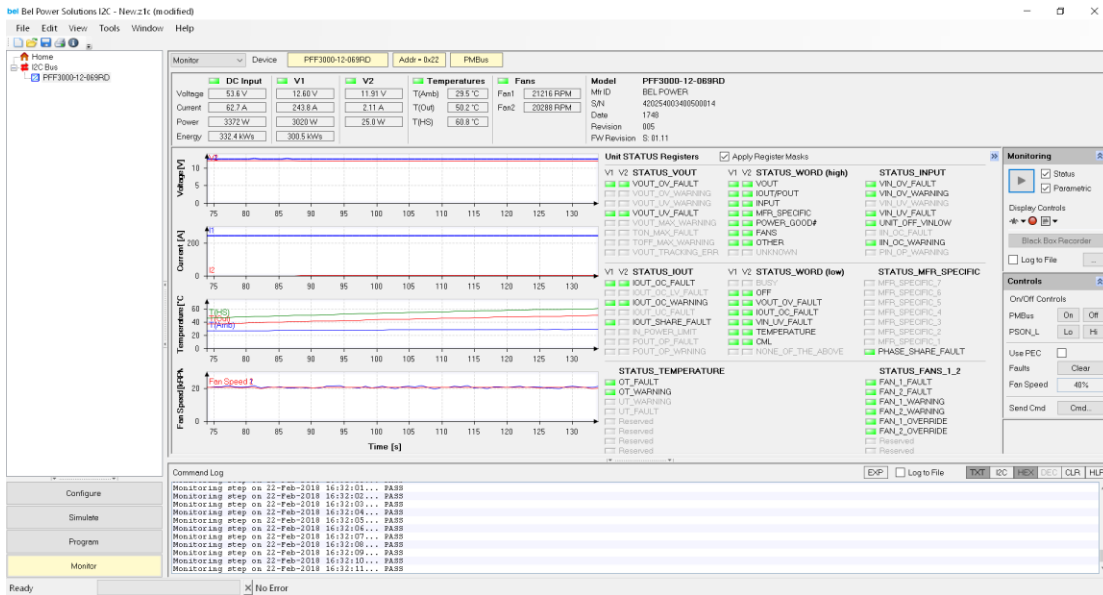

Figure 23. Monitoring dialog of the I2C utility (example)

9. TEMPERATURE AND FAN CONTROL

In order to achieve best cooling results, sufficient airflow through the supply must be ensured; airflow shall not be blocked or obstructed by placing large objects close to the output connector at the rear of the supply. PFF3000-12-069RD is provided with a front-to-rear airflow, thus meaning the air enters through the power supply handle side (front) and leaves at the rear side. PFF3000-12-069RD has been designed for horizontal operation. The internal fan is controlled by a microprocessor: fan rpm is then adjusted to provide optimal cooling air and is a function of output power, inlet and internal MOSFETs temperature.

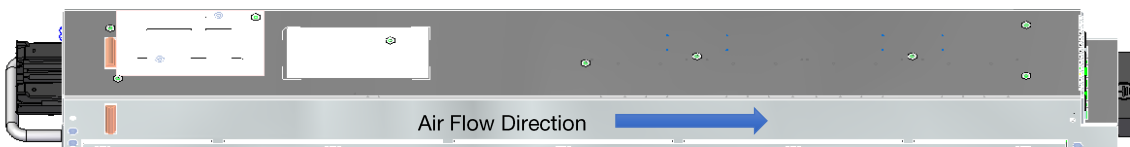

Figure 24. Airflow direction

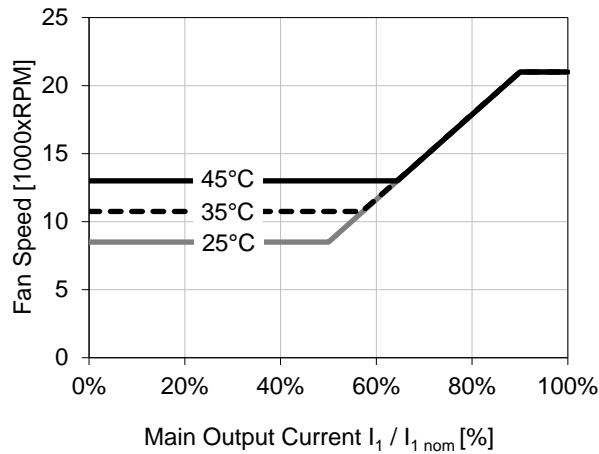

Figure 25. Fan speed vs. main output load

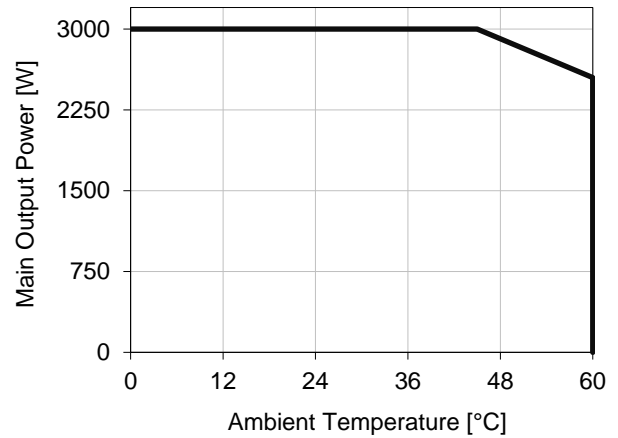

Figure 26. Thermal power derating

10. ELECTROMAGNETIC COMPATIBILITY

10.1 IMMUNITY

NOTE: Most of the immunity requirements are derived from EN 55024:1998/A2:2003.

PARAMETER	DESCRIPTION / CONDITION	CRITERION
ESD Contact Discharge	IEC / EN 61000-4-2, ± 8 kV, 25 + 25 discharges per test point (metallic case, LEDs, connector body)	A
ESD Air Discharge	IEC / EN 61000-4-2, ± 15 kV, 25 + 25 discharges per test point (non-metallic user accessible surfaces)	A
Radiated Electromagnetic Field	IEC / EN 61000-4-3, 10 V/m, 1 kHz / 80% Amplitude Modulation, 1µs Pulse Modulation, 10 kHz...2GHz	A
Burst	IEC / EN 61000-4-4, level 3, DC port ± 1kV, 1 minute	A
Surge	IEC / EN 61000-4-5 Line to earth: level 2, ± 1kV Line to line: level 3, ± 1kV	A
RF Conducted Immunity	IEC / EN 61000-4-6, level 3, 10 V _{rms} , CW, 0.1... 80 MHz	A

10.2 EMISSION

PARAMETER	DESCRIPTION / CONDITION	CRITERION
Conducted Emission	EN55022 / CISPR 22: 0.15... 30 MHz, QP and AVG	Class A
Radiated Emission	EN55022 / CISPR 22: 30 MHz... 1 GHz, QP	Class A
Acoustical Noise	Sound power statistical declaration (ISO 9296, ISO 7779, IS9295) load	@ 50 % 60 dBA

11. SAFETY / APPROVALS

Maximum electric strength testing is performed in factory according to IEC / EN 60950 and UL 60950. Input - to - output electric strength tests should not be repeated in the field. Bel Power Solutions will not honour any warranty claims resulting from electric strength field tests.

PARAMETER	DESCRIPTION / CONDITION	CRITERION
Agency Approvals	Approved to the latest edition of the following standards: <ul style="list-style-type: none"> • IEC60950-1 2nd edition (CB) • EN60950-1 2nd Edition (Nemko) • UL/CSA0950-1 2nd Edition (cCSAus) 	Approved by independent body (see CE declaration)
Isolation Strength	Input (DCIN+ / DCIN-) to case (PE)	Basic
	Input (DCIN+ / DCIN-) to output	Basic
	Output to case (PE)	Functional
Creepage / Clearance	Primary (DCIN+ / DCIN-) to protective earth (PE)	According to safety standard
	Primary to secondary	
Electrical Strength Test	Input to case	According to safety standard
	Input to output	
	Output and signals to case	

12. ENVIRONMENTAL

PARAMETER	DESCRIPTION / CONDITION	MIN	NOM	MAX	UNIT	
T _A	Ambient temperature	V _{i min} to V _{i max} , I _{1 nom} , I _{SB nom} at 4000 m		0	+40 *	°C
		V _{i min} to V _{i max} , I _{1 nom} , I _{SB nom} at 1800 m		0	+45	°C
T _{Aext}	Extended temperature range	Derated output		+45	+55	°C
T _S	Storage temperature	Non - operational		-40	+70	°C
	Altitude	Operational, above sea level		-	4000	m
	Relative humidity	Operational: T _A = 40 °C		7	85	%
Non-Operational		5	93	%		
N _a	Audible noise	V _{i nom} , 50 % I _{o nom} , T _A = 25 °C at by-stander position		60		dBA
	Cooling	System back pressure		0.5		in H ₂ O
Shock	IEC60068-2-27	Operational:	11ms, half-sine	7		g pk
		Non-Operational:	11ms, half-sine	30		
Vibration	IEC60068-2-27	Operational:	Swept-sine, 5-500-5 Hz	1		gpk
		Non-Operational:	Swept-sine, 5-500-5 Hz	4		
		Random, 10-500 Hz	3.5			
Fall test	IEC60068-2-32	Edge drop, Corner drop, topple		1		m

NOTE: * System airflow will assist the PSU airflow

13. MECHANICAL

PARAMETER	DESCRIPTION / CONDITION	MIN	NOM	MAX	UNIT
Dimensions	Width	69		mm	
	Height	42		mm	
	Depth	555		mm	
m	Weight	2.66		kg	

NOTE: A 3D step file of the power supply casing is available on request.

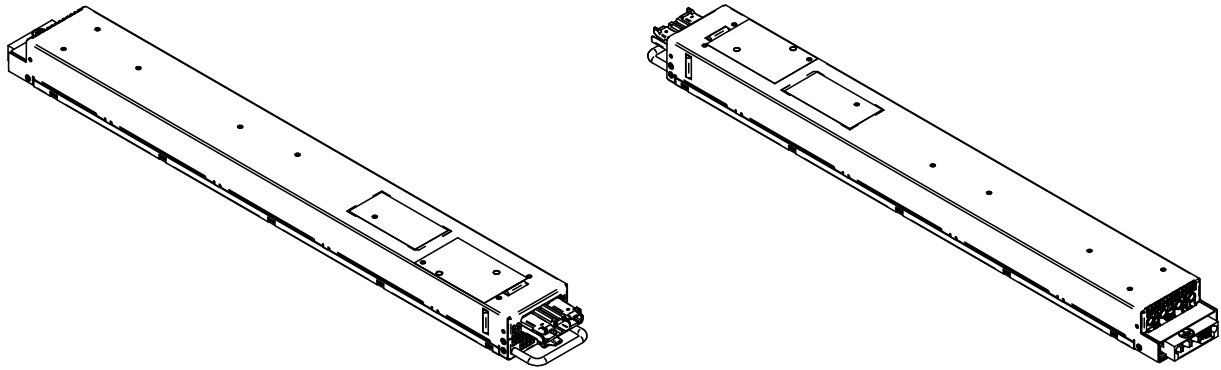

Figure 27. ISO front and rear view

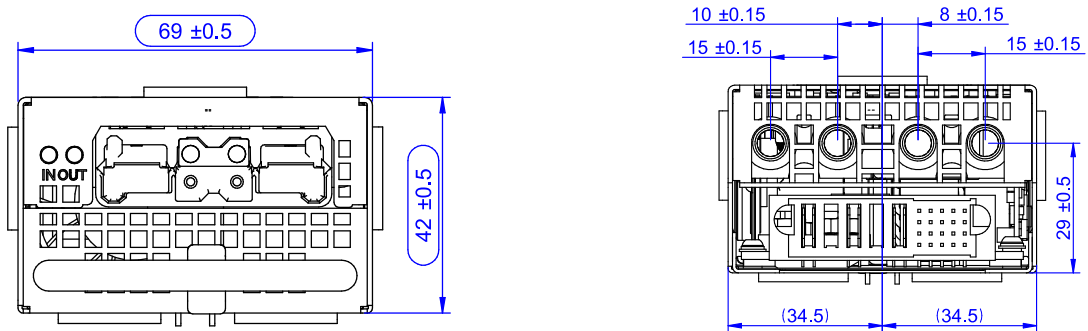

Figure 28. Front and rear view

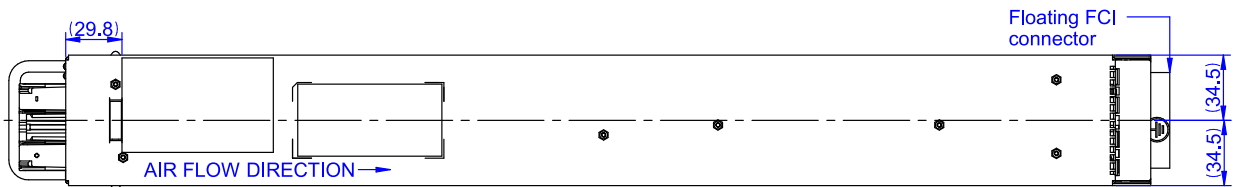

Figure 29. Top view

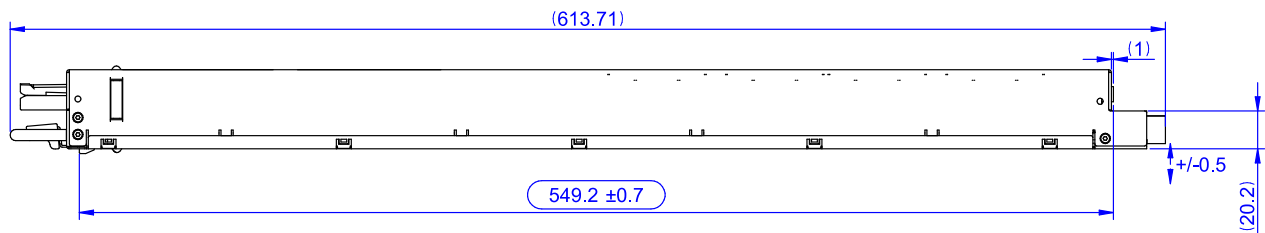
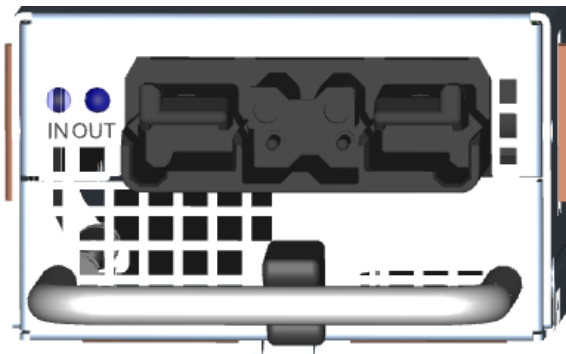

Figure 30. Front and rear view

14. CONNECTORS

Input



IN1	Aux1	Aux2	IN2
	Aux3	Aux4	

Connector: Anderson Power SBS75XPRBLK-BK
 Counterpart:
 Housing: Anderson Power SBS75XBLK
 Power pins IN1/2 (AWG6): Anderson Power 1339G2
 Sockets Aux1/2 (AWG24-20): Anderson Power PM16S2024S32

Output

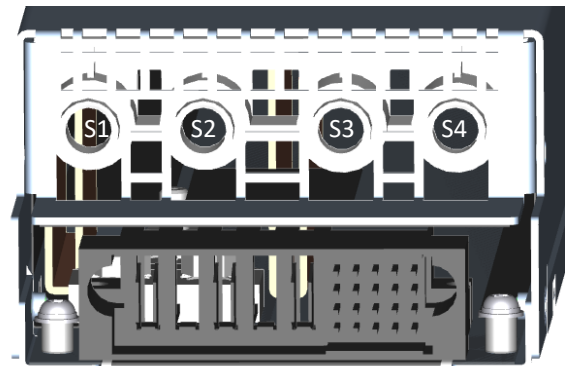

S1		S2		S3		S4			
P1	P2	P3	P4	P5	D1	D2	D3	D4	D5
					C1	C2	C3	C4	C5
					B1	B2	B3	B4	B5
					A1	A2	A3	A4	A5



Connector: Amphenol/FCI 51939-768LF
 Counterpart: Amphenol/FCI 51915-401LF
 A1 and A2 are trailing pins (short pins)
 For main output pins (S1-S4), see section 14

14.1 INPUT CONNECTOR PINOUT

PIN	NAME	DESCRIPTION
<i>Input Power</i>		
IN1	DCIN-	Input voltage negative
IN2	DCIN+	Input voltage positive
<i>Input Signals</i>		
Aux1	reserved	
Aux2	reserved	
Aux3	PSKILL_IN_L	Input connector power supply kill
Aux4	SGND	Signal ground

Table 7. Input Connector Pinout

14.2 OUTPUT CONNECTOR PINOUT

<i>Output</i>			
S1, S2	PGND	+12 VDC main output ground	
S3, S4	V1	+12 VDC main output	
<i>PE</i>			
P1		Protective Earth	
P2	empty	-	
P3		Protective Earth	
P4	empty	-	
P5		Protective Earth	
<i>Output Signals</i>			
A1	PSKILL_L	Power supply kill (trailing pin):	active low
B1	PWOK_L	Power OK signal output:	active low
C1	INOK_L	Input OK signal:	active low
D1	PSON_L	Power supply on input:	active low
A2	PRESENT_L	Power supply present (trailing pin):	active low
B2	SGND	Signal ground * (return)	
C2	SGND	Signal ground * (return)	
D2	SGND	Signal ground * (return)	
A3	SCL	I2C clock signal line	
B3	SDA	I2C data signal line	
C3	SMB_ALERT_L	SMB alert signal output:	active low
D3	ISHR_BUS	V1 current share bus	
A4	EEPROM_WP	EEPROM Write protect	
B4	RSVD	Reserved	
C4	V1_SNS_R	Main output negative sense	
D4	V1_SNS	Main output positive sense	
A5	VSB	Standby positive output	
B5	VSB	Standby positive output	
C5	VSB_R	Standby ground *	
D5	VSB_R	Standby ground *	

NOTE: * These pins should be connected to SGND on the system.
See section 7 for pull-up resistor settings of signal pins - All signal pins are referred to SGND.

Table 8. Output Connector Pinout

15. SHELF LEVEL CONFIGURATION (PROVISIONAL)

See also SPSPFF3-01 datasheet BDC.00887

The recommended pin configuration below is based on company's own Shelf design and provided here as reference. Customer pin lengths within the range indicated is acceptable.

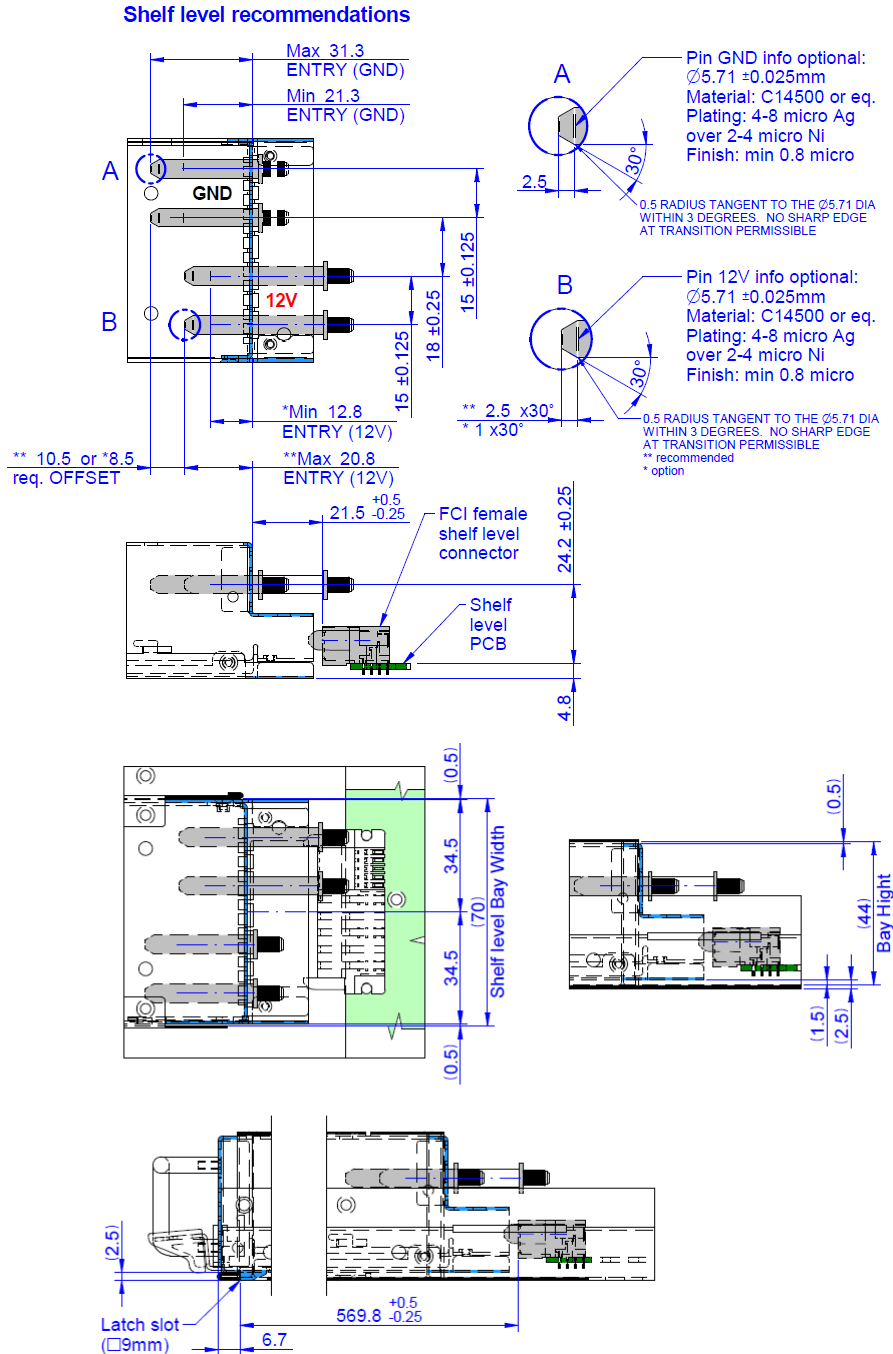

16. ACCESSORIES

ITEM	DESCRIPTION	ORDERING PN	SOURCE
	I²C Utility Windows Vista/7/8 compatible GUI to program, control and monitor PFE Front-Ends (and other I ² C units)	N/A	belfuse.com/power-solutions

17. REFERENCES

DOCUMENT NUMBER	DESCRIPTION
BCA.00447	PFF3000-12-069RD Installation Instruction
BCA.00216	PFF3000-12-069RD Power Management Bus Communication Manual
BCD.00887	Power Shelf SPSPPF3-01G datasheet
BCD.00820	NAC2006-01 datasheet

18. REVISION HISTORY

REV	DESCRIPTION	PSU PRODUCT VERSION	DATE	AUTHOR
008	First release version		Jan-2018	RK/MS
011	Product photo updated; Output and Protection table update; Added EEPROM and Power Management Bus Protocol chapters; General unification with PFE3000 product		Mar-2018	RK/MS
AA	Update readback and protection table, release to AA		June-2018	
AB	Update input voltage from positive to negative values, Correct (swap) Pi and Po readback tolerances		Aug-2018	RK
AC	Remove preliminary watermark			

For more information on these products consult: tech.support@psbel.com

NUCLEAR AND MEDICAL APPLICATIONS - Products are not designed or intended for use as critical components in life support systems, equipment used in hazardous environments, or nuclear control systems.

TECHNICAL REVISIONS - The appearance of products, including safety agency certifications pictured on labels, may change depending on the date manufactured. Specifications are subject to change without notice.



Asia-Pacific	Europe, Middle East	North America
+86 755 298 85888	+353 61 225 977	+1 408 785 5200